

**VOLVO
PENTA**

POWERBOAT 2018

The latest innovations, engines, drivelines and options

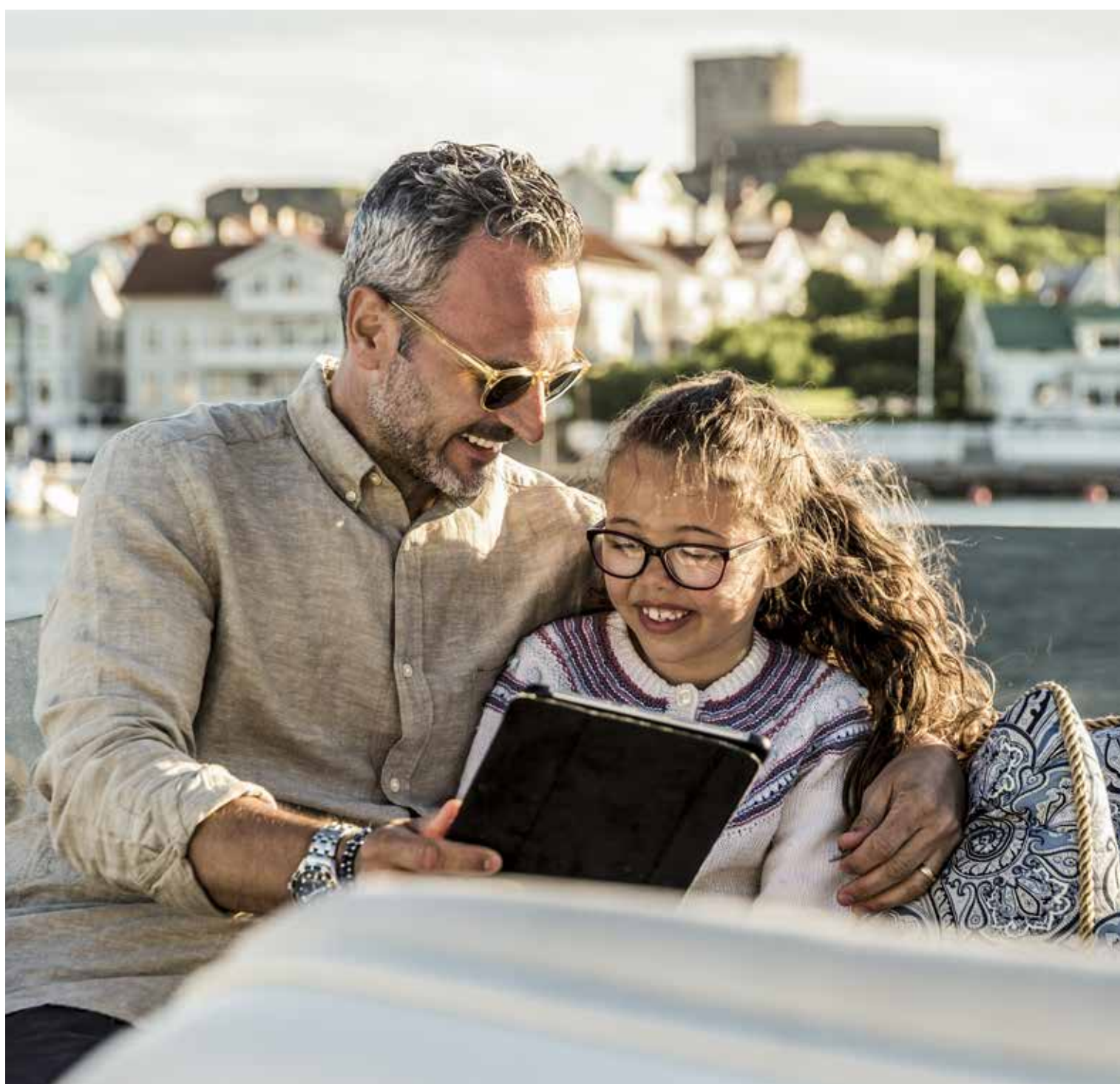



WATER SPORT CONTROL PAGE 5

CONTENTS

- 3 THE SMARTER WAY TO EASY BOATING
- 4 HIGHLIGHTS
- 6 VOLVO PENTA DRIVER INTERFACE
- 8 EASY BOATING FEATURES
- 10 **VOLVO PENTA IPS** - JOIN THE BOATING REVOLUTION
- 14 **AQUAMATIC STERNDRIVE** - THE SPORTY CHOICE
- 19 REPOWERING - MADE EASY
- 20 **FORWARD DRIVE** - A NEW DIRECTION OF FUN
- 22 **INBOARD SHAFT** - ENGINES FOR SUPERIOR CRUISING
- 24 SERVICE AND SUPPORT
- 25 PARTS AND ACCESSORIES
- 26 SPECIFICATIONS

Alternatively, for more information go to volvopenta.com.



D13-IPS1350 PAGE 4



VOLVO PENTA EASY CONNECT PAGE 5

The smarter way to Easy Boating

When we talk about Easy Boating, we refer to something that is more than a philosophy. It's actually a way of life – a constant thread that runs through everything we do, so that you can relax and enjoy every special moment on the water.

In the world of Volvo Penta, our contribution to your relaxation and enjoyment comes from developing safe, reliable and proven technology for use onboard your boat. It's been our mission for over a century. And this year is no exception.

For 2018 we've launched our most powerful engine yet – the Volvo Penta D13-1000. Available in either IPS or Inboard Shaft configurations, it is a perfect example of Easy Boating. With 1000hp available and exceptional low-end torque, the entire driveline has been redesigned for class-leading performance, durability and

comfort. A level of attention-to-detail and engineering pedigree that only Volvo Penta can deliver.

Indeed all the products available this year are smarter solutions designed for your life onboard – all innovative in their own unique way and always ready to do exactly what you ask of them. Intuitively. At any moment.

This is the smarter way to Easy Boating.



A level of attention-to-detail
and engineering pedigree that
only Volvo Penta can deliver.

Highlights

Whether we are increasing choice, upgrading features or introducing new products, this year there is something for everyone onboard. Our new app – Volvo Penta Easy Connect – delivers vital information direct to your smart devices. And if you're looking for the perfect water sport experience, Water Sport Control is designed to deliver exactly that. No news, however, would be complete without mentioning the all-new Volvo Penta D13 engine – with 1000hp available it's our most powerful engine ever. Its arrival extends our range of class-leading drivelines to give you more choice than ever before.

Reduced emissions

The new D13 engine conforms to the latest U.S. EPA Tier 3 and EU RCD stage 2 standards, keeping emissions to a minimum.

Electronic Vessel Control (EVC)

Our electronic platform integrates engines, transmission and electronics to offer the best driver experience available.



Twin-turbo power

The perfect partnership delivering outstanding low-end torque that is maintained throughout the rev range.

Perfectly matched

Designed for maximum performance and durability, the upgraded pod works in perfect harmony with the new D13 engine.

New D13 engine for IPS and Inboard shaft

The new Volvo Penta D13 engine takes high-performance and reliability to a whole new level. Available for Volvo Penta IPS (D13-IPS1350) or for Volvo Penta Inboard shaft (D13-1000), the new D13 engine pushes out 1000hp at 2400rpm. And what is more, the design modifications that deliver reliability and performance have also been applied across our entire engine range.





Volvo Penta Easy Connect

Connected technology is the latest exciting addition to everyone's life onboard. As a boat owner, the Volvo Penta Easy Connect app gives you a dashboard-style overview of your boat's vital information directly to your smart devices – whether you're at home or onboard. As a passenger, you can monitor and save routes with the possibility to share them on social media – while still keeping a curious eye on speed and heading. But as you'd expect from Volvo Penta, there are practical functions built in to Easy Connect. For example, should your driveline need a service or an inspection, you can easily share your information and status with your preferred Volvo Penta service dealer. You're connected. And it's so easy*.



Battery Management System

This year the Battery Management System has become even more intuitive. You can still manage your onboard battery power, but now there is even better functionality built into the e-Key remote. It's now even easier to remotely switch power on or off, and – via the two programmable buttons – control functions such as exterior lighting, heating or media equipment from the dockside. At the heart of system is the Battery Control Module (BCM) that makes installation, operation and maintenance easy.



Water Sport Control

Get the most out of your water sport activities by viewing and controlling boat speed and drive trim. Water Sport Control automatically maintains a constant boat speed using GPS signals. Preset and store your favorite setups – for different activities and users. It's conveniently packaged in the Glass Cockpit display to work with a rear camera view and a music interface.

*Available at the start of 2018



Volvo Penta driver interface

Once again, Volvo Penta has created a new standard. With the Glass Cockpit System as a central feature, we have realized our vision of a completely new, marine driver environment.

Inspired by the knowledge and experience of the Volvo Group – one of the world's most prominent manufacturers of driver environments – we have focused on making the interface between you and your boat as simple, easy and intuitive as possible.





5

4

1. Propulsion and navigation in one

Available from 7 to 24-inch widescreen format, the Glass Cockpit System integrates all driver information in one location.



The multi-function, touchscreen displays give you a full overview of navigation and engine data, together with Easy Boating functions such as Autopilot, Joystick Driving and Water Sport Control. The displays are integrated with buttons on the throttle and joystick controls allowing you to switch between preset layouts - increasing your safety, awareness and enjoyment at sea.

2. The power of a single e-Key

With the e-Key panel you only need one key to lock and unlock the system. Swipe the e-Key in front of the panel or press the ON button on the e-Key Remote and the system powers up - authorizing you as the user of the boat. You can also program the e-Key Remote to operate on specific onboard functions such as deck and interior lighting or an automated gangway.

3. Intuitive handling

Volvo Penta Joysticks make driving and docking easier than ever. With an optional joystick for Volvo Penta IPS, Aquamatic Sterndrive and Diesel Inboard-powered boats, driving and docking have never been easier. The buttons put a unique combination of functions within easy reach.

4. An ergonomic success

All Volvo Penta controls are ergonomic with a solid high-quality feel. On this top-mounted control, all EVC functions are activated and adjusted via easily accessible buttons - for increased comfort, better drivability and enhanced safety.

5. Steering in style

Volvo Penta's selection of steering wheels combines high quality with a stylish design that is perfectly matched to our range of EVC controls and displays. Available in different stainless steel models and combined with mahogany or leather.

Easy Boating features

Whether it's an intuitive electronic interface or a high-performance drive system, every piece of Volvo Penta equipment is developed with you in mind - enhanced integration and usability that's designed to make your life on the water even more relaxing and enjoyable.

Joystick control - available for all systems

Aquamatic, Volvo Penta IPS and now Inboard shaft installations can benefit the advantages of precision maneuverability. Regardless of which propulsion system you choose, you can add useful features such as Joystick Docking and Joystick Driving.

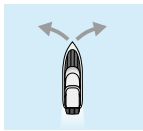

Joystick Driving

A whole new way to maneuver with precision at all speeds. You steer comfortably with the joystick. The integrated autopilot supports by automatically engaging after every course change.

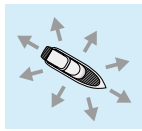

Joystick Docking

Makes docking easy, even fun. Forget complicated maneuvers in close quarters. Just move the joystick in any direction and your boat will follow. You can install up to six Joystick Docking stations on your boat.



Features

	Volvo Penta IPS	Aquamatic Sterndrive	Forward Drive	Inboard Shaft
Joystick Docking	●	● 2)	-	● 2)
Joystick Driving	●	● 2)	-	● 2)
Dynamic Positioning System	●	-	-	-
Battery Management System	●	●	●	●
Sportfish Mode	●	-	-	-
Autopilot	●	● 2)	-	● 2)
Volvo Penta Interceptor system	●	● 2)	-	●
Powertrim Assistant	-	●	●	-
Water Sport Control	-	● 4)	● 4)	-
Tow mode	-	● 1)	●	-
Glass Cockpit System	●	●	●	●
Trip computer	●	●	●	●
Cruise control	●	●	●	●
Single-lever Mode	●	● 2)	-	●
Low-speed Mode	●	-	-	● 3)

● Available - Not available 1) Single installations 2) Twin installations 3) D4-D13 4) Single gasoline installation

Dynamic Positioning System

With Volvo Penta IPS, the Dynamic Positioning System is the perfect feature when you want to maintain your position for a moment. For example, when you are preparing for docking, waiting to refuel or for a bridge or lock to open. Just press the DPS button and the system will hold your boat's heading and safely keep it within a very limited area, even during strong currents or windy conditions.



Volvo Penta Interceptor system

The robust and compact design of the trim system ensures efficient and reliable trimming for Volvo Penta-powered boats 35–100+ foot. Fully integrated with EVC, it has become the perfect Auto-mode solution. Fully automatic trim adjustments will make your driving easier than ever.



Cruise control

With fingertip control of your engine rpm, you can fine-tune your boat's speed for best possible fuel economy and comfort.



Low-speed Mode

Reduces boat speed at idling by 50% from 5–6 knots to 2–3 knots. Integrated in the control. Perfect when you're driving in marinas and canals.



Glass Cockpit System

Gathers all driver information in one place – for enhanced overview and instant control of both navigation and engine.



Battery Management System

The system gives you a complete overview of battery status, helping you to manage your onboard electrical system.

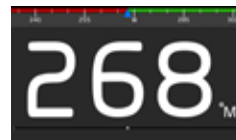

Autopilot

EVC-integrated, locks automatically to steering wheel course changes (shadow drive).

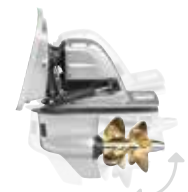

Powertrim Assistant

Gives you the best possible drive trim – fully automatically – for perfect running attitude. Results in optimum performance and low fuel consumption.



Trip computer

Get trip computer functionality with information about fuel consumption, distance to empty, trip time and much more for optimizing your boat's performance.



Sportfish Mode

Makes it possible for you to rapidly turn your boat around its own axis – and follow the fish at high speed in reverse, using only the engine controls.



Water Sport Control

View and control your boat's speed and trim. The display works with a rear-view camera and music interface.



Single-lever Mode

Operate twin, triple or quad engines with only one lever. Gives you easy control over speed even in rough seas.

VOLVO PENTA IPS



Join the boating revolution

The Volvo Penta IPS revolution continues with the launch of our most powerful version ever – the D13-IPS1350. New this year, it exemplifies the extraordinary lengths Volvo Penta will go to in order to deliver superior performance, while maintaining the signature maneuverability and comfort of IPS. Our engineers have reworked the entire driveline to deliver a system that is perfectly matched for maximum reliability – just like the rest of the IPS range. In fact, you could say there has never been a better time to join the revolution.

Key characteristics

Maneuverability, onboard comfort and performance – Volvo Penta IPS takes these characteristics to a whole new level. In addition, the layout of IPS creates more usable space onboard and has influenced many of the world's leading boat designers.

The benefits of Volvo Penta IPS

- 40% longer cruising range
- 20% higher top speed
- 30% reduced fuel consumption
- 30% less CO₂ emissions
- 50% lower perceived noise level
- Safe and predictable handling
- Reduced vibrations
- Joystick control
- Creates more space onboard

These are approximate figures comparing IPS with inboard shafts at cruising speed with planing hulls.



Faster, further, cleaner and quieter

Volvo Penta IPS is designed to improve all aspects of propulsion. The numbers speak for themselves. Forward-facing, counter-rotating propellers reduce CO₂ emissions by 30%, while also reducing fuel consumption and perceived noise levels.

And that's not all. Together with the latest Volvo Penta engines you get 20% more speed, together with a 40% longer cruising range.

The joystick

The joystick is perhaps the most well-known feature of Volvo Penta IPS, putting outstanding maneuverability and a unique combination of functions within easy reach. Dynamic Positioning, Joystick Driving, Joystick Docking and High Mode all offer easier handling and increased safety.

Forward-facing technology

The key to the outstanding efficiency of the Volvo Penta IPS pod system is in the configuration itself. The twin counter-rotating propellers are mounted together in a forward-facing position to work in undisturbed water. So when you engage the throttle, the power pulls the boat forward through the water rather than pushing it – putting world-class maneuverability at your fingertips.

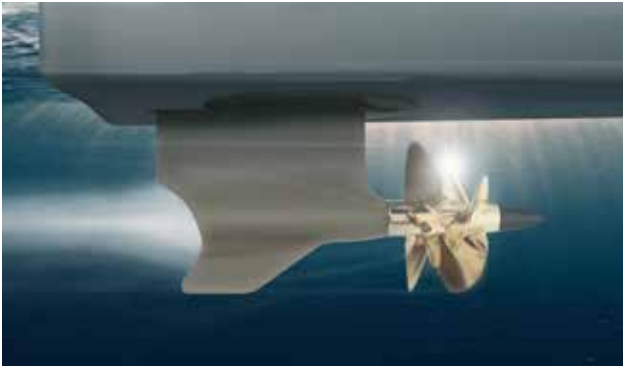

Increased performance. Reduced emissions.

Forward-facing propellers considerably improve on-board comfort and reduce emissions at the stern. All exhaust fumes are emitted through the pods, into the prop wash and carried well behind the boat. Cavitation is not a problem as propellers are positioned well under the hull; air intrusion is stopped, even in sharp turns and during full acceleration.

Stronger components

Reliability is assured with upgraded pistons, camshafts, injectors and cooling systems, while retaining the same compact design as the current D13-900.

Superior performance

Open the throttle and the D13-IPS1350 unleashes 1000hp and 3527Nm of torque at 2400rpm.

Increased comfort

Noise levels and vibrations are reduced using rubber suspension and seals to absorb thrust and propulsion forces.

35% higher efficiency

The forward-facing solution and an efficient flat-surface planing hull give around 35% higher efficiency at fast cruising than inboard shafts.

Upgraded Pod

Handles more power. Increased durability and reliability with upgraded gears and bearings to perfectly match the output of the new D13 engine.

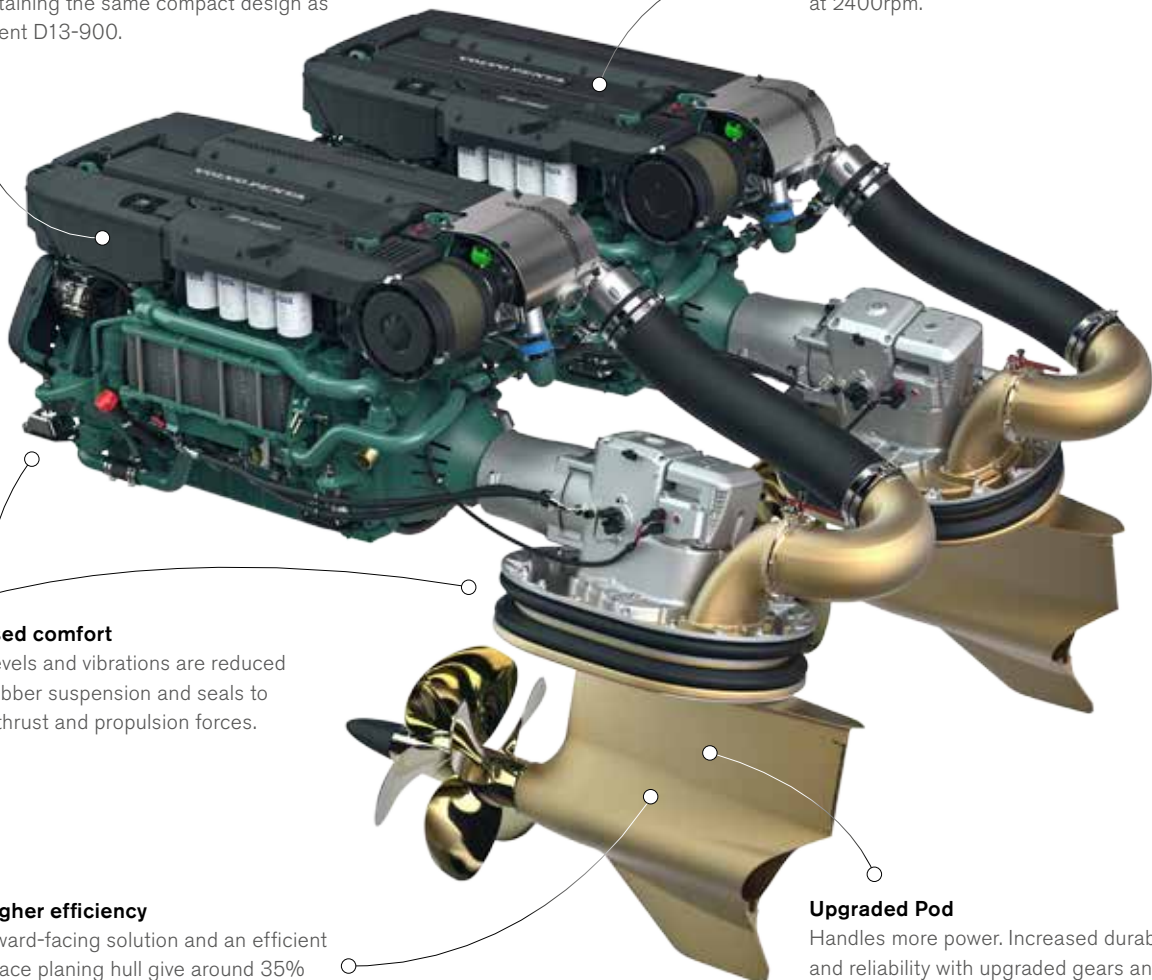



Steerable pods

Steerable pods harness the thrust and point it in the desired direction. This gives an immediate response and totally predictable handling.

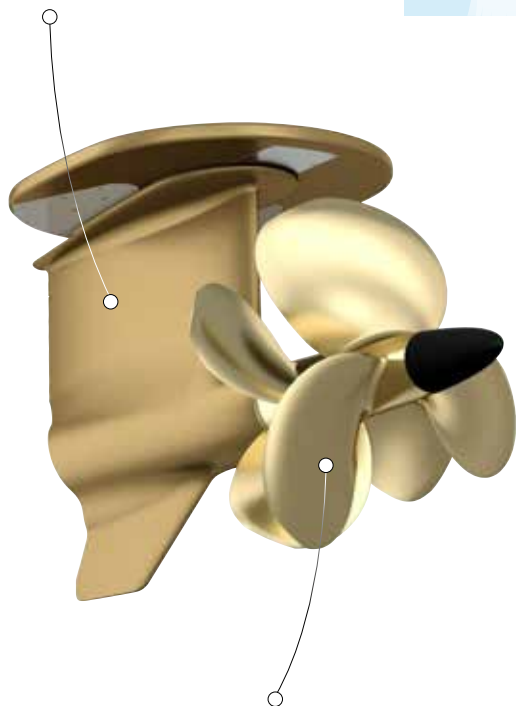
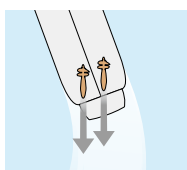

Minimal hub for maximum blade area

With Volvo Penta IPS, the exhaust doesn't go through the propeller hub. The minimal hub diameter results in a larger active blade area and thus, a significantly better grip in the water.

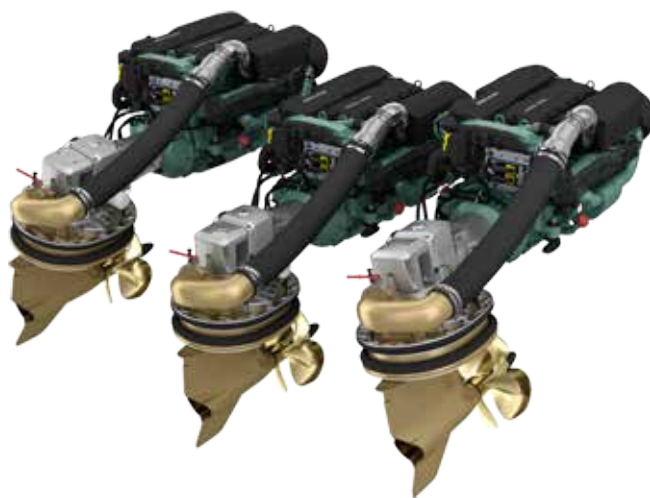

Multiple installations

Volvo Penta IPS is available in twin, triple and quadruple installations. Suitable for a wide range of boat designs, the lighter and more compact engine installation delivers a superior power-to-weight ratio. This results in a smaller engine room and more space for accommodation.

AQUAMATIC STERNDRIVE



The sporty choice

The Aquamatic Sterndrive is the world's leading sterndrive. In its own unique way, this well-proven system offers a total solution for boaters seeking the ultimate combination of performance, driving experience and comfort in 20-45ft boats.

It's a perfectly matched package – cleverly thought through from the controls to the engine and all the way to the drive and propellers. Aquamatic Sterndrive is available with a wide range of fuel-efficient yet sporty diesel and gasoline engines.

The benefits of the Aquamatic Sterndrive

- Low fuel consumption
- DuoProp propellers
- Low CO₂ emissions
- Low noise and vibrations
- Excellent low-speed maneuverability
- Beach and shallow-water tilt
- Uncluttered transom
- Joystick control
- Powertrim Assistant



Increasing efficiency

An Aquamatic Sterndrive with DuoProp propellers achieves the same efficiency as Volvo Penta IPS – both reduce fuel consumption by up to 30% compared to inboard shaft installations.



The sterndrive joystick

The buttons on the joystick put a unique combination of functions within easy reach. Joystick Driving, Joystick Docking and High Mode offer easier handling, increased safety and more fun.



Powertrim Assistant

Powertrim Assistant can be synchronized with the Interceptor System in an Aquamatic application. This automatically gives the best possible drive trim. The result is maximized comfort regardless of speed and maneuvers, together with low fuel consumption.

The Aquamatic evolution

The Aquamatic Sterndrive system is perfectly matched for optimal performance. Since introducing the first version in 1959, Volvo Penta has continued to evolve the design by developing, testing and manufacturing the whole package – the key to the outstanding efficiency. To improve your boating experience further, you can choose from a wide range of options for easier and more comfortable boating.

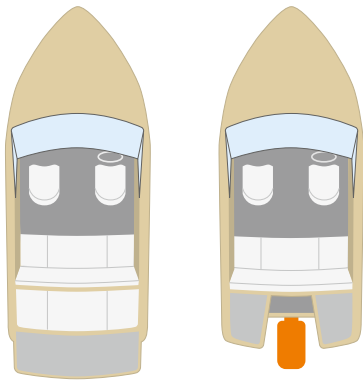

Sterndrive vs. Outboards

An Aquamatic Sterndrive gives you a number of advantages over a standard outboard installation. Firstly, flexibility and design: Placed further forward and with improved weight distribution, the concealed engine bay of a Sterndrive makes for a better and more flexible use of space – either above for a sundeck or behind for a swim platform. Secondly, the performance: With power steering as standard, the boat is easy to handle. Together with DuoProp, this gives the boat outstanding maneuverability and performance. As Sterndrives are located in the hull, you gain more options for larger engine displacement and therefore more amounts of torque. This translates into less strain on the engine, better fuel economy and a longer life cycle.



Volvo Penta Gasoline sterndrives with catalysts produce up to 94% less carbon monoxide than the marine industry outboard standard.

D6-400 DPH

Six cylinder diesel engines that utilize the latest in modern diesel technology.

Electronic Vessel Control (EVC)

Our electronic platform integrates the engine, transmission and electronics to offer the best driver experience available.

DPH drive

Maximum driving pleasure from the perfectly matched DuoProp drive.



Supercharging

Superchargers are mated to the large capacity engines delivering a unique spread of torque throughout the entire RPM range.

DuoProp

DuoProp high-strength nibral propellers – specially developed for the Volvo Penta DPH drive.



Your command center for a perfect ride

With Volvo Penta's range of controls you easily form your complete command center. That means comfortable and ergonomic control of all essential functions like electronic shift and throttle, integrated buttons for engine and drive functions, Powertrim control in the lever and individual Powertrim buttons (twin installation).

Drivelines – for the perfect match

Our propulsion packages are designed to operate in perfect harmony – an engine and driveline that can convert Volvo Penta-generated torque into superior power and performance in the water.

The complete package

We develop, design and manufacture everything for the ultimate statement in reliability and performance. We've had this complete-package approach for almost 60 years. It's the only way.

DuoProp technology

The twin counter-rotating propellers grip hard to produce unparalleled thrust, acceleration, planing and handling with significantly lower vibration and noise levels.

The power to move you

The technology in our newest generation of V6 and V8 gasoline engines is meant to move you. Performance upgrades and improved fuel economy moves us. But we'd rather you notice the smiles on your family's faces. Or the way the wind whips your hair at full throttle. Or the sound of your wake lapping against the shoreline at dusk. Rest assured, our latest generation of sterndrive engines are engineered for technical superiority, but they are also designed with fun in mind. Your fun.

Easy Drain

Designed with an anti-siphon vent, the engine can drain raw water while the boat is still in the water – at the push of a single knob and without disconnecting any water hoses.

Variable Valve Timing

Improved response and acceleration across the RPM range.

Catalyst for very low emissions

Reduces CO emissions by up to 94%. (See page 16).

Fresh-water cooling

All our gasoline engines come with fresh-water cooling, which means no salt or raw water exposure to any engine parts.

Direct fuel injection

The move from multi-port technology to direct injection creates a cleaner burn and improved fuel economy. So more energy comes from each drop of fuel.

Simplified service points

Volvo Penta's next generation gasoline engines share common parts and common service locations on the engine unit, across the full lineup.



The new V8-380/V8-430 gasoline engines.

The power and efficiency generation

Robust low-end torque. Exhilarating high-end power. Exceptional mid-range response. All gasoline engines now include direct fuel injection, Variable Valve Timing (VVT) and fresh-water cooling. With this year's addition of the new 6.2L V8 in both 380 and 430hp outputs, our range of latest generation V6 and V8 engines is now complete.



Water Sport Control

Get the most out of your water sport activities by viewing and controlling boat speed and drive trim. Water Sport Control automatically maintains a constant boat speed using GPS signals. Preset and store your favorite setups – for different activities and users. It's conveniently packaged in the Glass Cockpit display to work with a rear camera view and a music interface.



The glory of repowering

Has your boat lost some of its former power and glory? A simple and economical way to significantly improve your boat's overall performance – and take your boating life to a new level – is to simply replace its engine. Volvo Penta's repowering kits for D1, D2 and D3 engines will help you make a cost-effective transition to the latest generation of diesel engines.

A multitude of benefits

Installing a new engine will increase the value of your boat, but above all, it will very tangibly improve your boat's performance. Maneuverability will improve along with onboard comfort thanks to quieter operation and lower vibration levels. Fuel consumption and emission levels will drop thanks to modern technology. You will also benefit from increased charging capacity and overall reliability, and – last but not least – the Volvo Penta 2+3 years warranty.

Easy installation

The repowering kits are developed by Volvo Penta and have been thoroughly tested, ensuring a safe, easy, and cost-effective replacement. Every kit is made to match and cause minimal impact to your existing engine bed. All parts and components are included along with complete installation instructions.

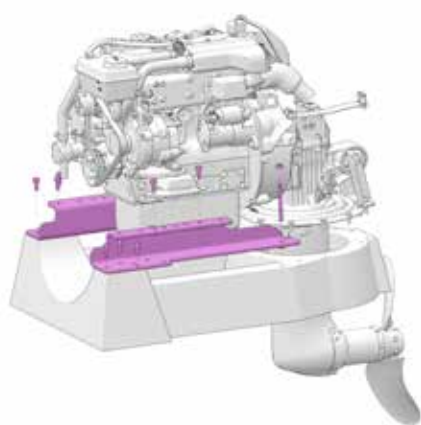

D1/D2 Repowering kit

The D1/D2 Repowering kit is available for Volvo Penta engines in both shaft and Saildrive installations. A set of perfectly matched components will minimize time-consuming fiberglass work.

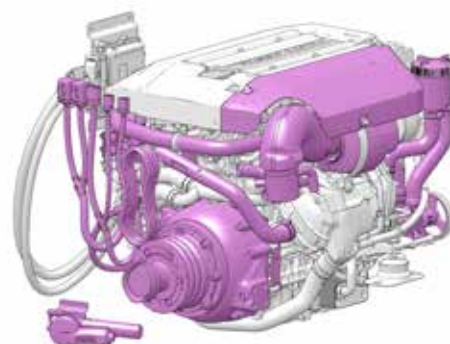

D3 Repowering kit

The D3 Repowering kit offers a perfect match between the new D3 diesel engine and your existing Volvo Penta drive, offering full EVC functionality and access to a wide range of accessories.



VOLVO PENTA FORWARD DRIVE

A new direction of fun

Volvo Penta Forward Drive – the new standard for getting the most fun out of your boat. Twin counter-rotating, forward-facing propellers pull the boat rather than push it for higher top speeds, faster acceleration and superior maneuverability. And maybe a quickened pulse. The result is a propulsion system capable of big wakes, smooth cruises and everything in between.

Clean and efficient propulsion

Powerful gasoline engines complete the propulsion system with less noise and low-level vibration. And now you can enjoy wakesurfing, fishing or simply relaxing at the stern as exhaust fumes are eliminated with ports that run down through the drive and exit underwater.

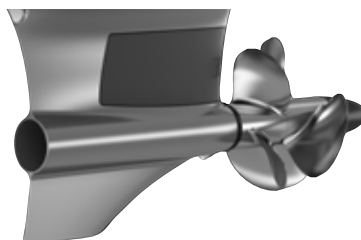

DuoProp – unparalleled thrust

Twin counter-rotating propellers bite hard to produce unparalleled thrust, straight and true tracking plus faster acceleration on the plane.

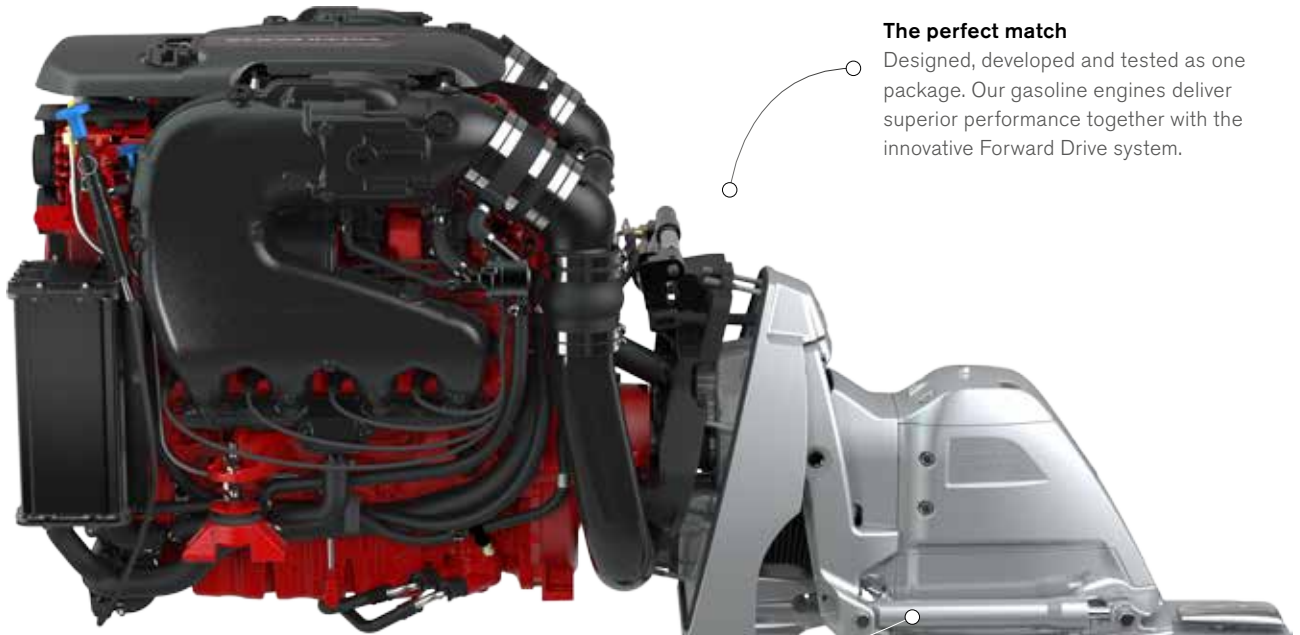

The perfect match

Designed, developed and tested as one package. Our gasoline engines deliver superior performance together with the innovative Forward Drive system.

Performance

Variable trim angles provide the right thrust for leisure cruising as well as top speeds. And when speeding to plane it is much faster than conventional inboards. Turns are much tighter and faster thanks to directional thrust.

DuoProp

Stainless steel DuoProp propellers interact with each other to evenly distribute torque under load.

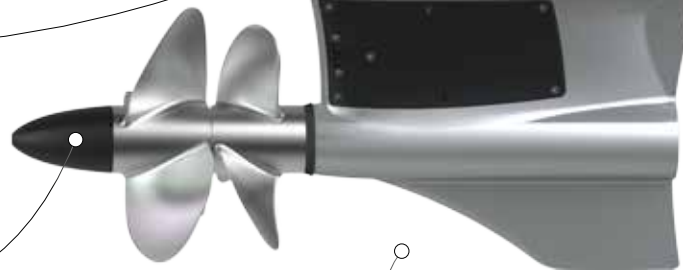

Totally versatile

With Forward Drive boaters enjoy hours of fun wakesurfing, wakeboarding and fishing or simply cruising around.

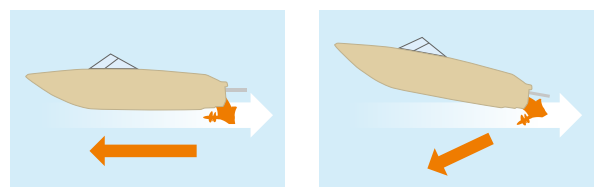

Your command center for a perfect ride

With the Volvo Penta range of controls you easily form your complete command center. That means comfortable and ergonomic control of all essential functions like electronic shift and throttle, integrated buttons for engine and drive functions and Powertrim control are all in the lever and have a manual override.

Powertrim Assistant

Powertrim allows drivers to customize their water sports experience with an adjustable angle of thrust. Variable, downward thrust draws the stern lower into the water. Used in combination with an enlarged trim plate, it fine-tunes your wake surfing wave and wakeboarding wakes on the fly. When on the move, the trim allows effortless, comfortable cruising.

INBOARD SHAFT



Engines for superior cruising

Volvo Penta diesel engines for inboard shaft installations have always been about drivability and comfort. Unique marine torque and rapid acceleration, combined with a class leading power-to-weight ratio, means they always deliver. This year the range becomes even more diverse with the new D13-1000 putting 1000hp at the fingertips of boat owners worldwide. In other words, cruising just got even more superior, without sacrificing durability or reliability.

Joystick makes handling easy

The joystick is the latest addition to controls for twin inboard installations making handling and docking easier for inboard boat owners. It connects the rudder with the gear, throttle and thrusters. The advanced Electronic Vessel Control system converts driver inputs across all four functions for outstanding maneuverability while docking or driving.



D13-1000

The new Diesel Inboard engine delivers 1000hp and 3527Nm of torque at 2400rpm. Impressive figures from our most powerful inboard engine ever.

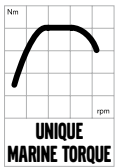

Unique marine torque

The Volvo Penta engines' unique marine torque gives efficient cruising speed in all conditions: rapid acceleration to the plane and maneuvering power at low rpm and increased full-throttle torque if the engine loses rpm at high rpm.



From 12 to 1000hp

From the compact D1 to the massively powerful D13, Volvo Penta's inboard range consists of eight different engine sizes with various power levels – you can always find one that's perfectly matched to your boat.

Low-speed Mode

Reduce your boat's speed at idling by approximately 50% for easier maneuvering and docking. Integrated in the standard controls.



Single-lever Mode

Drive twin engines with one lever. Easy and precise even in rough seas.



Autopilot

EVC-integrated, locks automatically to steering wheel course changes (shadow drive).

See the complete range of Easy Boating options for Inboard Shaft on page 8.

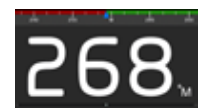



Service and support

With Volvo Penta engines and accessories you are well prepared for enjoyable and safe boating. With only one contact for the whole package, you have the full support of the Volvo Penta service network. Our dealers are always ready to assist – and help maximize your boating time and pleasure.

Global service network

With every Volvo Penta product comes the support of a worldwide dealer network – present in more than 130 countries. Certified technicians, trained in the latest Volvo Penta technology, expertly carry out maintenance and repair work – and always with Genuine Volvo Penta Parts.

One point of contact

With Volvo Penta, you need just one point of contact for the whole package: engines, instruments, accessories, service, warranties, etc. This means simpler ownership – and easy boating.

International Limited Warranty

A warranty for boat owners and occasional boat-sharing arrangements. In the first 2 years, or the applicable number of running hours, our engine and transmission warranty commitment covers the complete engine package. In the following 3 years, it covers major components.

Extended Coverage

Extended Coverage for the complete Volvo Penta engine package is a complement to our International Limited Warranty. By offering repair or replacement of defective parts also for the years 3–5, it will keep you fully protected even after the standard warranty has expired. The Extended Coverage must be purchased in conjunction with warranty registration.



Find your dealer

Go to www.volvopenta.com/dealerlocator or download our app to search among our 3,500 dealers worldwide.



Volvo Penta Action Service

Our global dealer network is backed up by the Volvo Penta Action Service, offering assistance 24 hours a day, every day of the year in 28 languages. www.volvopenta.com/actionservice.



Yacht series support

As an owner of a yacht powered by a Volvo Penta IPS500–600 in a triple or quadruple application or an IPS700–1350 in a twin, triple or quadruple installations, you are eligible for the Volvo Penta Yacht Series Support; an exclusive, around-the-clock support program that is fully on par with your propulsion system installation – and your vessel. More at: www.volvopenta.com/yss.

Parts and accessories

Our range of parts and accessories are designed and engineered to the highest standards and built to work in perfect harmony with your Volvo Penta engine and transmission. We call these Genuine Volvo Penta Parts and Accessories. And when you fit them, you can count on optimum performance, reliability and long service life.

Customize your boating

With such a comprehensive range of accessories perfectly matched to your engine and driveline, it is easier than ever to customize your boat's maneuverability, comfort and safety. Our range starts at the helm with steering wheels, instruments and displays, and continues under deck with items for engines including pre-fuel filters and extra alternators. Moving under water, we provide active corrosion protection and a complete range of state-of-the-art propellers.

Double your warranty

Genuine Volvo Penta Parts and Accessories are covered by our standard 12-month warranty. Have them supplied and installed by an authorized Volvo Penta dealer and we'll extend your warranty to 24 months – including the labor. Consult your nearest dealer for more details.



Volvo Penta shop

More than 100,000 parts and accessories are available to you in the Volvo Penta web shop at www.volvopentashop.com.



Volvo Penta Easy Connect

Route information, heading, battery voltage and so much more, shared to your smart devices. Read more at: www.volvopenta.com/easyconnect.



Inboard shaft

Engines	Crankshaft kW/hp	Propeller shaft kW/hp	Rated rpm	Displacement liters	No. of cylinders	High-pressure fuel injection	Aspiration	Electronic management	Constant power	Electronic shift/throttle	Freshwater cooling	Alternator 12V	Alternator 24V	Saildrive
D1-13	9.0/12.2	8.6/11.8	3200	0.5	2	-	N	MDI	-	-	●	115A ¹⁾	-	130S
D1-20	14/19	13/18	3200	0.8	3	-	N	MDI	-	-	●	115A ¹⁾	-	130S
D1-30	20/27	19/26	3200	1.1	3	-	N	MDI	-	-	●	115A ¹⁾	-	130S
D2-40	27/37	26/36	3200	1.5	4	-	N	MDI	-	-	●	115A ¹⁾	-	130S
D2-50	37.5/51	36/49	3000	2.2	4	-	N	MDI	-	-	●	115A ¹⁾	-	130S
D2-60	44/60	42/58	3000	2.2	4	-	T	MDI	-	-	●	115A ¹⁾	-	150S
D2-75	55/75	53/72	3000	2.2	4	-	T	MDI	-	-	●	115A ¹⁾	-	150S
D3-110	81/110	78/107	3000	2.4	5	CR	T/A/4V	EVC	T/Q	●	●	180A	-	-
D3-150	110/150	106/144	3000	2.4	5	CR	T/A/4V	EVC	T/Q	●	●	180A	-	-
D3-170	125/170	121/165	4000	2.4	5	CR	T/A/4V	EVC	T/Q	●	●	180A	-	-
D3-200	147/200	143/194	4000	2.4	5	CR	T/A/4V	EVC	T/Q	●	●	180A	-	-
D3-220	162/220	157/213	4000	2.4	5	CR	T/A/4V	EVC	T/Q	●	●	180A	-	-
D4-180	132/180	128/174	2800	3.7	4	CR	T/A/4V	EVC	T/Q	●	●	115A ¹⁾	-	-
D4-225	165/225	160/218	3500	3.7	4	CR	T/A/4V	EVC	T/Q	●	●	115A ¹⁾	-	-
D4-260	191/260	186/253	3500	3.7	4	CR	T/A/4V	EVC	T/Q	●	●	115A ¹⁾	-	-
D4-300	221/300	212/288	3500	3.7	4	CR	T/A/4V	EVC	T/Q	●	●	115A ¹⁾	-	-
D6-330	243/330	237/322	3500	5.5	6	CR	T/A/4V	EVC	T/Q	●	●	115A ¹⁾	80A ¹⁾	-
D6-370	272/370	267/363	3500	5.5	6	CR	T/A/4V	EVC	T/Q	●	●	115A ¹⁾	80A ¹⁾	-
D6-435	320/435	310/422	3500	5.5	6	CR	T/A/K/4V	EVC	T/Q	●	●	115A ¹⁾	80A ¹⁾	-
D6-435 WJ	320/435	-	3500	5.5	6	CR	T/A/4V	EVC	T/Q	●	●	115A ¹⁾	80A ¹⁾	-
D8-550	405/550	392/534	2900	7.7	6	CR	T/A/4V	EVC	T	●	●	-	80A ¹⁾	-
D8-600	441/600	428/582	3000	7.7	6	CR	T/A/4V	EVC	T	●	●	-	80A ¹⁾	-
D11-625	460/626	446/607	2400	10.8	6	UI	T/A/4V	EVC	T	●	●	-	80A ¹⁾	-
D11-670	493/670	478/650	2450	10.8	6	UI	T/A/4V	EVC	T	●	●	-	80A ¹⁾	-
D11-725	533/725	517/703	2500	10.8	6	UI	T/A/4V	EVC	T	●	●	-	80A ¹⁾	-
D13-800	588/800	562/765	2300	12.8	6	UI	T/A/4V	EVC	T	●	●	-	110A ¹⁾	-
D13-900	662/900	636/864	2300	12.8	6	UI	T2/A/4V	EVC	T	●	●	-	110A ¹⁾	-
D13-1000	735/1000	706/960	2400	12.8	6	UI	T2/A/4V	EVC	T	●	●	-	110A ¹⁾	-

Volvo Penta IPS

IPS350	191/260	182/248	3500	3.7	4	CR	T/A/K/4V	EVC	T/Q	●	●	115A ¹⁾	-
IPS400	221/300	212/289	3500	3.7	4	CR	T/A/K/4V	EVC	T/Q	●	●	115A ¹⁾	-
IPS450	243/330	230/314	3500	5.5	6	CR	T/A/K/4V	EVC	T/Q	●	●	115A ¹⁾	80A ¹⁾
IPS500	272/370	259/352	3500	5.5	6	CR	T/A/K/4V	EVC	T/Q	●	●	115A ¹⁾	80A ¹⁾
IPS600	320/435	307/418	3500	5.5	6	CR	T/A/K/4V	EVC	T/Q	●	●	115A ¹⁾	80A ¹⁾
D8-IPS700	405/550	384/523	2900	7.7	6	CR	T2/K/4V	EVC	T	●	●	-	80A ¹⁾
D8-IPS800	441/600	419/570	3000	7.7	6	CR	T2/K/4V	EVC	T	●	●	-	80A ¹⁾
IPS800	460/625	435/591	2400	10.8	6	UI	T/A/K/4V	EVC	T	●	●	-	80A ¹⁾
IPS950	533/725	504/685	2500	10.8	6	UI	T/A/K/4V	EVC	T	●	●	-	80A ¹⁾
IPS1050	588/800	554/753	2300	12.8	6	UI	T2/A/4V	EVC	T	●	●	-	110A ¹⁾
IPS1200	662/900	624/848	2300	12.8	6	UI	T2/A/4V	EVC	T	●	●	-	110A ¹⁾
D13-IPS1350	735/1000	693/942	2400	12.8	6	UI	T2/A/4V	EVC	T	●	●	-	110A ¹⁾

1) With built-in charging sensor

Volvo Penta Forward Drive

Engines with catalytic converter	Crankshaft kW/hp	Max rpm	Displacement liters	No. of cylinders	Fuel injection	Electronic management	Electronic shift/throttle	Freshwater cooling	Alternator 12V	Drive	Propellers ¹⁾
V6-240-C	179/240	5800	4.3	V6	DI	EGC/EVC	○	●	75A	FWD	SS
V6-280-C	209/280	5800	4.3	V6	DI	EGC/EVC	○	●	75A	FWD	SS
V8-300-C	224/300	5800	5.3	V8	DI	EGC/EVC	○	●	75A	FWD	SS
V8-350-C	261/350	5800	5.3	V8	DI	EGC/EVC	○	●	75A	FWD	SS
V8-380-C	283/380	6000	6.2	V8	DI	EGC/EVC	○	●	75A	FWD	SS
V8-430-CE	321/430	6000	6.2	V8	DI	EVC	●	●	75A	FWD	SS

● Standard ○ Standard or optional depending on market - Not available 1) Not included
For availability, check with your Volvo Penta representative.

Diesel Aquamatic Sterndrive

Engines	Crankshaft kW/hp	Propeller shaft kW/hp	Rated rpm	Displacement liters	No. of cylinders	High-pressure fuel injection	Aspiration	Electronic management	Constant power	Electronic shift/throttle	Freshwater cooling	Alternator 12V	Drive	X-act steering	Propellers ³⁾
D3-140	103/140	98/133	4000	2.4	5	CR	T/A/4V	EVC	T/Q	●	●	180A	SX/DPS/OX ²⁾	-	AL ⁴⁾ , SS
D3-170	125/170	119/162	4000	2.4	5	CR	T/A/4V	EVC	T/Q	●	●	180A	SX/DPS/OX ²⁾	-	AL ⁴⁾ , SS
D3-200	147/200	140/190	4000	2.4	5	CR	T/A/4V	EVC	T/Q	●	●	180A	DPS/OX ²⁾	-	AL ⁴⁾ , SS
D3-220	162/220	154/209	4000	2.4	5	CR	T/A/4V	EVC	T/Q	●	●	180A	DPS/OX ²⁾	-	AL ⁴⁾ , SS
D4-225	165/225	158/215	3500	3.7	4	CR	T/A/4V	EVC	T/Q	●	●	115A ¹⁾	DPH	●	NBR
D4-260	191/260	184/250	3500	3.7	4	CR	T/A/K/4V	EVC	T/Q	●	●	115A ¹⁾	DPH	●	NBR
D4-300	221/300	214/291	3500	3.7	4	CR	T/A/K/4V	EVC	T/Q	●	●	115A ¹⁾	DPH	●	NBR
D6-330	243/330	233/317	3500	5.5	6	CR	T/A/4V	EVC	T/Q	●	●	115A ¹⁾	DPH	●	NBR
D6-370	272/370	261/355	3500	5.5	6	CR	T/A/K/4V	EVC	T/Q	●	●	115A ¹⁾	DPH	●	NBR
D6-400	294/400	281/382	3500	5.5	6	CR	T/A/K/4V	EVC	T/Q	●	●	115A ¹⁾	DPH	●	NBR

1) With built-in charging sensor 2) Water-in-Drive and Water-in-Bellows sensors are not available with diesel engines 3) Not included 4) Only for SX/DPS

Gasoline Aquamatic Sterndrive

Engines	Crankshaft kW/hp	Max rpm	Displacement liters	No. of cylinders	Fuel injection	Electronic management	Electronic shift/throttle	Freshwater cooling	Alternator 12V	Drive	Propellers ¹⁾
V6-200	149/200	5800	4.3	V6	DI	EGC	-	●	75A	SX/DPS	AL, SS
V6-240	179/240	5800	4.3	V6	DI	EGC	-	●	75A	SX/DPS/OX	AL ²⁾ , SS
V6-280	209/280	5800	4.3	V6	DI	EGC	-	●	75A	SX/DPS/OX	AL ²⁾ , SS

Engines with catalytic converter

V6-200-C	149/200	5800	4.3	V6	DI	EGC	-	●	75A	SX/DPS	AL, SS
V6-240-C	179/240	5800	4.3	V6	DI	EGC/EVC	○	●	75A	SX/DPS/OX	AL ²⁾ , SS
V6-280-C	209/280	5800	4.3	V6	DI	EGC/EVC	○	●	75A	SX/DPS/OX	AL ²⁾ , SS
V8-300-C	224/300	5800	5.3	V8	DI	EGC/EVC	○	●	75A	SX/DPS/OX	AL ²⁾ , SS
V8-350-C	261/350	5800	5.3	V8	DI	EGC/EVC	○	●	75A	DPS/OX	SS
V8-380-C	283/380	6000	6.2	V8	DI	EGC/EVC	○	●	75A	DPS/OX	SS
V8-430-CE	321/430	6000	6.2	V8	DI	EVC	●	●	75A	DPS/OX	SS

● Standard ○ Standard or optional depending on market - Not available 1) Not included 2) Only for SX/DPS
Check with your local Volvo Penta representative.

Abbreviations explained:

High-pressure fuel injection

UI: Unit injectors. **CR:** Common-rail fuel injection.

Electronic management

EVC: Electronic Vessel Control. **EGC:** Electronic Gas Control.

Aspiration

N: Naturally aspirated. **T:** Turbocharger. **T2:** Dual-stage turbochargers.

A: Aftercooler. **K:** Compressor. **4V:** 4 valves per cylinder.

Constant power

T: Temperature compensation. Constant power output regardless of fuel temperature (5–55°C). **Q:** Quality compensation. Constant power output regardless of fuel viscosity (heavy, regular or environmentally adapted fuel).

Fuel injection

DI: Direct injection.

Drive

SX: Single propeller. For gasoline engines and D3. Small transom cut-out. **DPS:** DuoProp. For gasoline engines and D3. Small transom cut-out. **DPH:** DuoProp. With X-act steering, specially developed for the D4 and D6 engines. Large transom cut-out. **OX:** OceanX. Includes exhaust manifolds, water-in-bellows sensor and drive oil quality sensor. **FWD:** Forward Drive. Forward facing, DuoProp. For gasoline engines only.

X-act steering

Servo-assisted hydraulic steering with external steering cylinders controlled by an exact feedback valve.

Propellers

AL: Aluminum. **SS:** Stainless steel. **NBR:** Nickel-bronze-aluminum alloy.

Power according to ISO 8665. Merchant fuel may influence engine power output and fuel consumption. For specific information on a certain engine model, ask your dealer for a Product Bulletin or go to volvopenta.com. Not all models, standard equipment and accessories are available in all markets. Every effort has been made to ensure that facts and figures are correct at the time of publication. Volvo Penta reserves the right to make changes without prior notice. Products shown may differ from production models.

**VOLVO
PENTA**

www.volvopenta.com